

DOPAK® Process Sampler Type S32-LG outage tube configuration (F3)

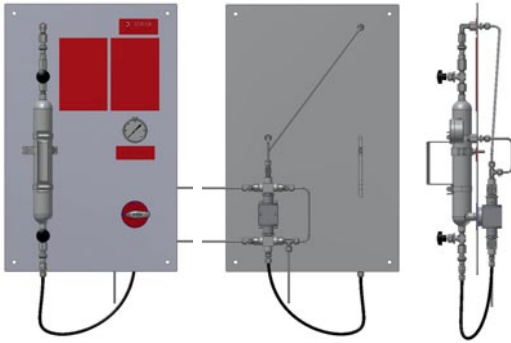

The ability to purge the sample point ensures optimal retrieval of a representative, contamination free sample. The S32-LG type samplers provide system purge in addition to sampling in a sample cylinder with a predefined filling rate. The predefined filling rate is achieved by using an outage tube in the sample cylinder. The unique design offers a one handle operation by multiple valves. These features provide sample accuracy and safety. This sampler type is suitable for liquefied gases and liquids.

1 OPERATION/FUNCTION

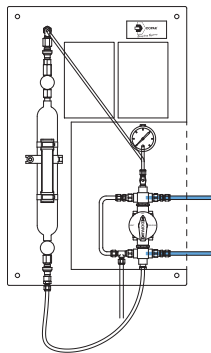

0 - off

Install the sample cylinder and connect the flexible hose to the bottom side of the sample cylinder. Open the needle valves on the sample cylinder.

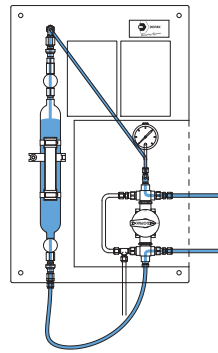

1 - system purge

Turn the handle to the "process" position, allowing the sample cylinder to be filled. The outage tube ensures a predefined filling rate. To ensure representative sample, this position can be held for any required time.

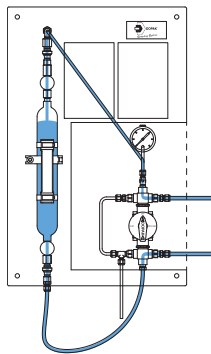

2 - off

Turn the handle to the "off" position. Close the two needle valves on the sample cylinder.

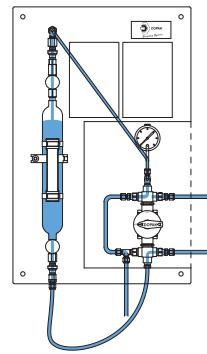

3 - depressurize/vent

Turn the handle to the "vent" position. The internal connection between the sample cylinder and the vent connection has now been made. The quick connects are being depressurized to the vent connection.

2 TYPICAL P & ID

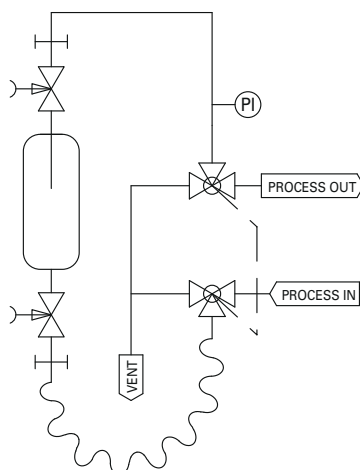

outage tube configuration (F3)

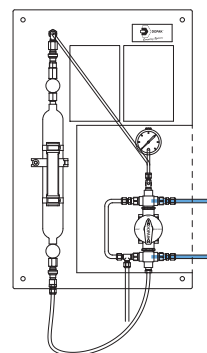

4 - off

Turn the handle to the "off" position. Disconnect the flexible hose. Remove the sample cylinder and connect the flexible hose to the top quick connect coupling.



3 FEATURES/ADVANTAGES/PROPERTIES

- Sampling in cylinder with predefined filling rate
- Representative sampling
- Zero dead volume
- Closed sampling
- One handle operation of mutiple valves
- Fixed volume sampling
- Purging of sampler
- No direct connection between vent line and process lines
- Depressurising of quick connect couplings

4 BASIC SPECIFICATIONS

Material	SS316, SS316L.	
Cylinder Type	500cc cylinder.	
Outage tube	Suited for 85% filling of sample cylinder.	
Valve	Three-way ball valve type W83. PTFE seats, Viton A O-rings. Pressure range 103 bar @ 20°C (1500 psig @ 70°F). Temperature range -17/+232°C (0/+450°F).	
Operation	Manual.	
Connections	1/4" FNPT.	
Please note:	the above is a basic specification only. DOPAK® Samplers can be offered with a wide variety of options as mentioned below.	

5 OPTIONS

- Spring return handle
- Lockable handle
- Pipe stand
- Block valve
- Flow meter
- Enclosure
- Sample cooler
- Exotic materials
- Larger/smaller sample size

For more information please refer to our sheets:

Options for DOPAK® process sampler, sampling into a cylinder.
Components for DOPAK® process samplers.

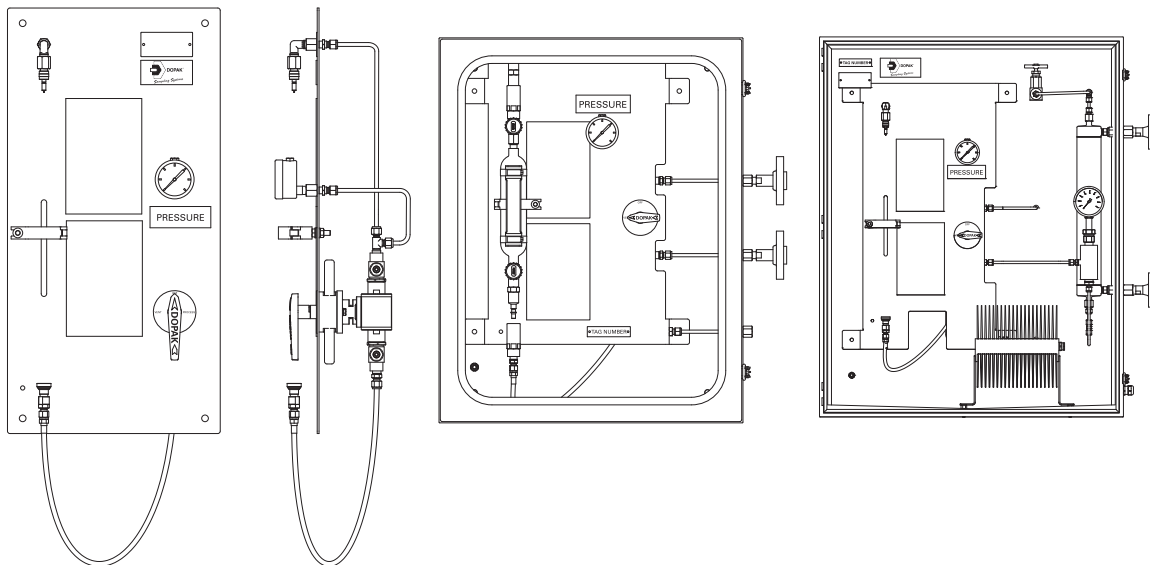

Dopak Inc.

Houston, Texas 77041, USA
 Phone 713-460-8311
 Fax 713-460-8578
 E-mail info@dopak.com

Dovianus BV

Bergschenhoek, The Netherlands
 Phone +31 10 524 20 00
 Fax +31 10 5624 20 29
 E-mail info@dopak.nl

Your local representative:

